



HG 02 GL



- Power Requirements** : 110/220V. 60/50Hz. AC (%±10) 24V. DC
Single Unit: At standby~10W. During operation ~39W.
Center Unit: At standby~20W. During operation ~78W.
- Wing Features** : RGB LED illuminated 10mm impact resistant tempered glass (Opt. polycarbon) wings.
- Body Features** : The body is made of 304-grade (Opt. 316-grade) satin finished stainless steel. Tempered glass (Opt. natural granite stone with Star Galaxy Black pattern) on top is standard feature for a decorative and aesthetical appearance (optionally other materials and patterns available).
- Operation Temperature, Humidity, IP Rating, MCBF** : -20°C to + 68°C / RH 95% non-condensing / IP 44 indoor model / 1M cycles
- Control System** : All inputs are opto-coupler protected. Compatible with all access control systems that provide dry contact or grounding outputs. Optional RS232/RS485/TCP IP control module is available.
- System Features & Operation** : Electronically controlled rapid wing movement for quick and smooth bi-directional passages. Internal dip switch selectable free passage by photocell detection, restricted access, controlled access on both or single direction modes are built in features.
- Emergency Mode** : System allows free passage in emergency mode and in case of power failure (powered by internal back-up battery).
- Flow Rate** : Wing opening speed/Time: 0,5 sec. wing closing speed/time: 0,5 sec.
Nominal: ~30 - 60 passages/minute (recommended reference figure).
*Utilisation of different access control units can change the flow rate.
- Standard Features** : RGB LED illuminated status indicators, tempered glass top lid.
- Optional Accessories and Applications** : Tempered glass side (lateral) panels, remote control unit, interface unit for PC, RS485, RS232 and LAN, counter, audio-messaging system, alarm sensor, floor mounting plate, coin slot/intelligent coin system and coin box, separator, card reader pole.
- Note** : A passage lane consists of min. 2 pieces of single units facing eachother.

HG 02 GL-S : SINGLE UNIT (LEFT or RIGHT)

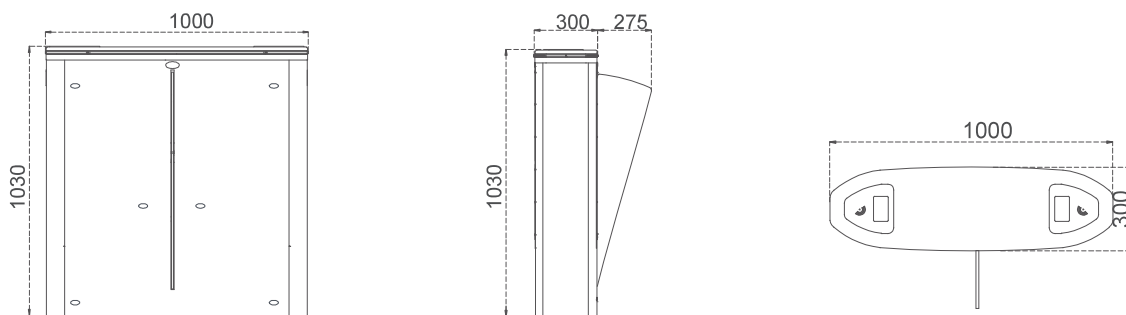

HG 02 GL-C: CENTER UNIT

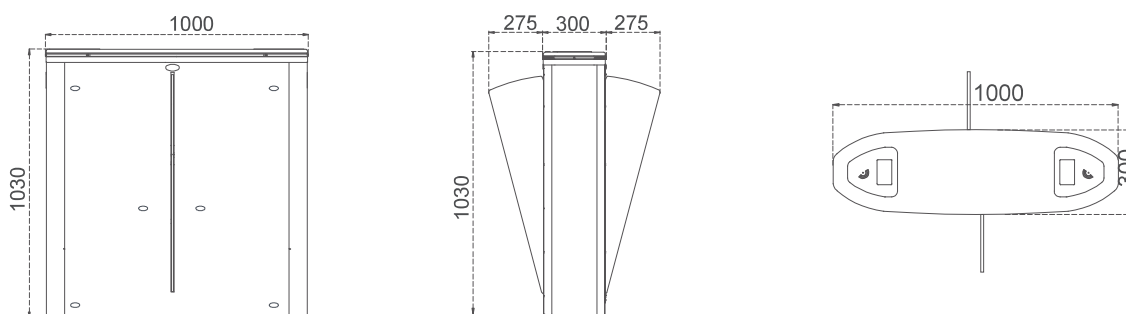

**Design and specifications are subject to change without notice. *All dimensions are in millimeters (mm).*

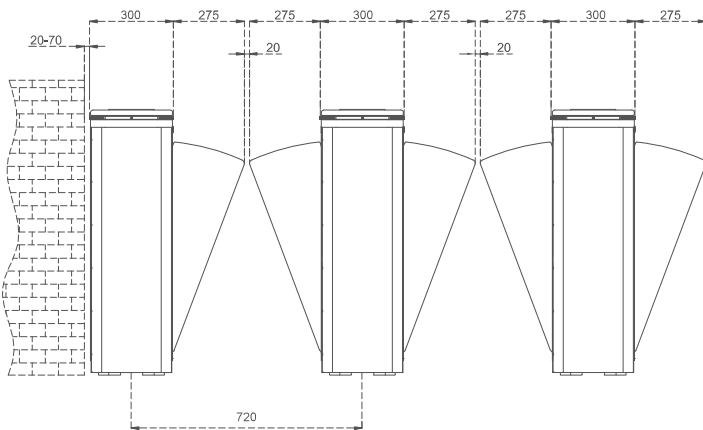
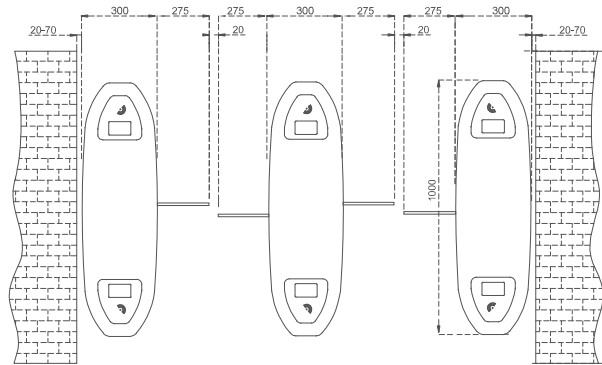
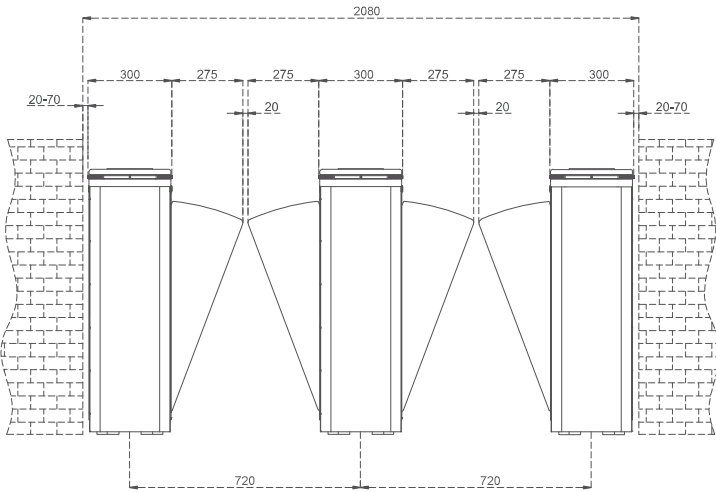
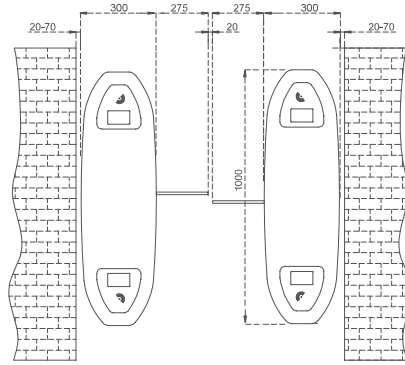
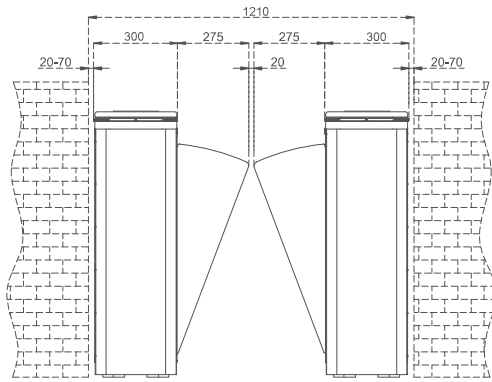

+... n ...+

