

BT 402 GL

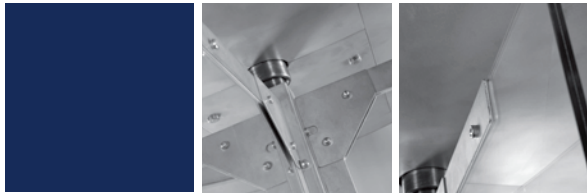

- Power Requirements** : 110/220V. 60/50Hz. AC (%±10) 24V. DC at standby ~6,8W. max. ~17W
- Wing Features** : Four-section rotor (90 degrees). Each section comprises 6+6mm laminated (Opt. tempered) glass revolving wings.
- Body Features** : The main frame structure is made of 304 grade stainless steel with 6+6 mm laminated (Opt. tempered) glass side walls. Water resistant top cover with matching stainless steel frame around. Service and maintenance from the ceiling of cabin.
- Operating Temperature, Humidity, IP Rating, MCBF** : -20°C to +68°C (Opt. -50°C with heater unit), RH 95% non-condensing / IP 54 outdoor model (Opt. IP 56) / 1M cycles
- Control System** : All inputs are opto-coupler protected. Controlled by dry contact or grounding input. Compatible with all access control systems that provide dry contact or grounding outputs. Optional RS232/RS485/TCP IP control module is available.
- Operation** : Manually operated bi-directional system (optional motorized) with dip switch selectable operational modes including controlled access on both sides, one side free (exit or entry) and other side controlled access and access restriction modes.
- Emergency Mode** : The rotor spins freely to allow free passage (fail-safe default). Fail lock option is available.
- Flow Rate** : Capacity of mechanism (manual system): ~60 passages/minute; nominal: ~18 passages/minute (recommended reference figure).
*Utilisation of different access control units can change the flow rate.
- Standard Features** : DOT matrix direction / status indicators, LED illuminated on the ceiling.
- Optional Accessories and Applications** : Remote control units (RF or with cable), interface unit for PC, RS485, RS232 and LAN, counter, audio-messaging system, floor mounting plate, card reader pole, animated indicators, internal battery and charge unit, heater positive unit, separators, card reader mounting bracket, photocell sensors for preventing unauthorized passage.

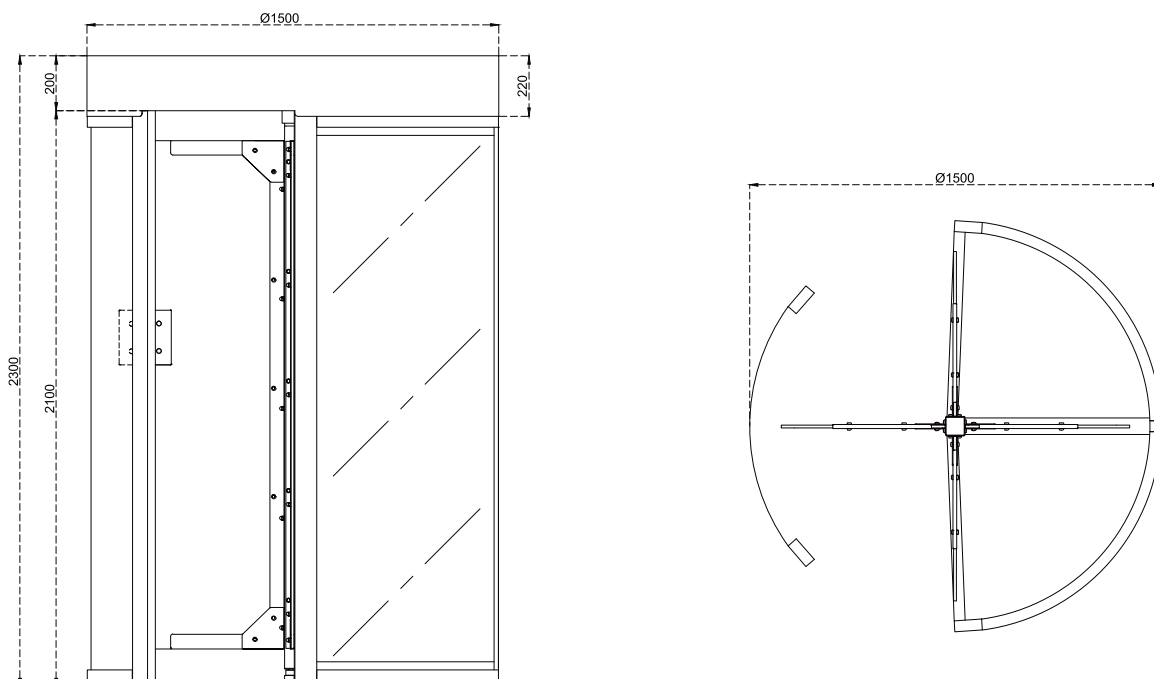

**Design and specifications are subject to change without notice. *All dimensions are in millimeters (mm).*