

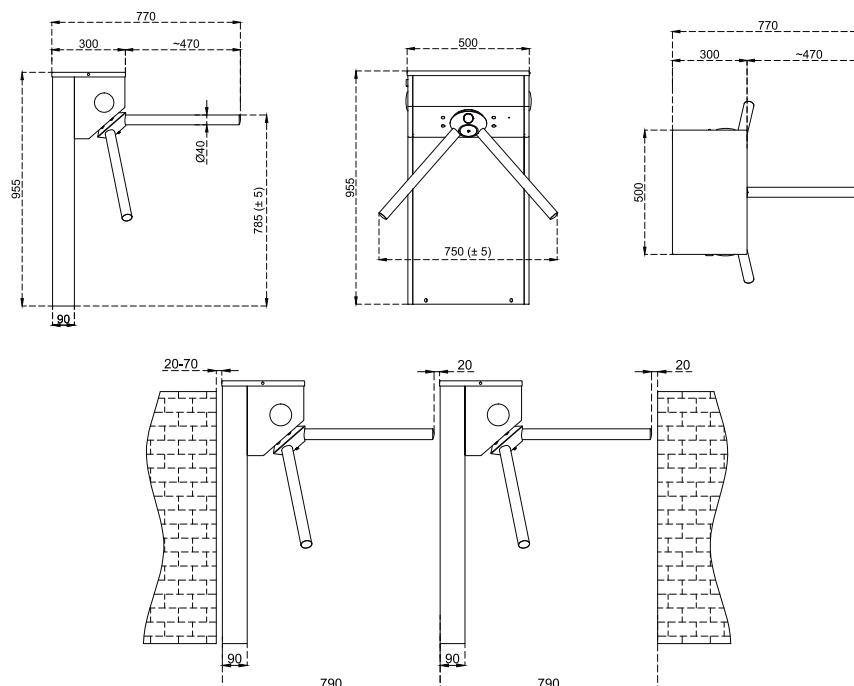

500 E



- Power Requirements** : 110/220 V. 60/50 Hz. AC (%±10) 24 V. DC at standby ~4,4 W. max. ~12 W.
- Arms** : Ø40 mm x 2 mm 304-grade stainless steel (Opt. 316 - grade stainless steel).
- Body Features** : 1,5 mm 304-grade (Opt. 316-grade) stainless steel with brushed (Opt. satin) surface.
- Operation Temperature, Humidity, IP Rating, MCBF** : -20°C to +68°C (Opt. -50°C with heater unit), RH 95% non-condensing / IP 54 outdoor model (Opt. IP 56) / 1M cycles
- Control System** : All inputs are opto-coupler protected. Compatible with all access control systems that provide dry contact or grounding outputs. Optional RS232/RS485/TCP IP control module is available.
- Operation** : Manually operated bi-directional system (optional motorized) with dip switch selectable operational modes including controlled access on both sides, one side free (exit or entry) and other side controlled access and access restriction modes.
- Emergency Mode** : System allows free passage in emergency mode and in case of power failure.
- Flow Rate** : Capacity of mechanism (manual system): max. 97 passages/minute, nominal: ~20 passages/minute
Capacity of mechanism (motorized system): max. 48 passages/minute, nominal: ~16 passages/minute
- Standard Features** : Direction and status indicators
- Optional Accessories and Applications** : Remote control units, interface unit for PC, RS485, RS232 and LAN, counter, audio-messaging system, motor driven unit, automatic drop (retractable) arm, alarm sensor, heater positive unit, coin slot/intelligent coin system and coin box, card reader pole, pipe barrier (separator), floor mounting plate, customised top covers to accommodate various accessories.



**Design and specifications are subject to change without notice. *All dimensions are in millimeters (mm).*