

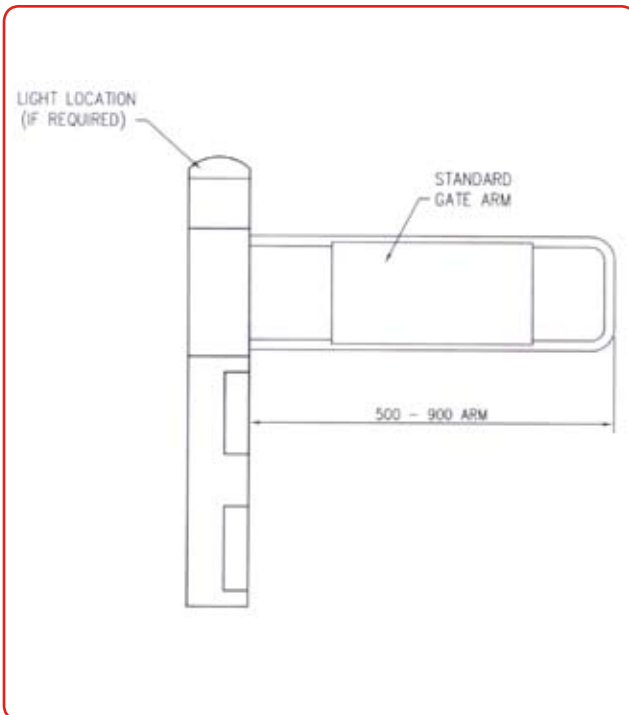

PEDESTRIAN
GATES

Rotogate with standard arm



The Rotogate offers a cost effective and versatile solution to controlling entrance/exit to any location. This simple, versatile design of the Rotogate presents a secure and stylish solution that compliments many locations, particularly those which experience high levels of pedestrian traffic. Our Rotogate is packed with many features that make access control more integrated and less obtrusive. It has the flexibility to be integrated with a variety of control systems from a simple manually operated push button to more sophisticated fully automatic ultrasonic, overhead sensors or autosensors or devices - see our information on control mechanisms for further information. Connection to a customer's own bespoke control system, e.g. fire alarm, computer system, etc. is also possible. Another great feature of the Rotogate is that it will automatically reset from the breakout position within 3 seconds (the breakout force required can be varied between 60-180 newton metres to suit environments) and has in-built intelligent software that activates a 'sleep mode' if it cannot perform a function after 3 failed attempts. The emergency breakout facility can be set up to activate an alarm and/or flashing top light to notify staff. The Rotogate is available in single left and right hand opening modes or double interconnecting units.

Control possibilities are:

Front Sensor options

- Single front photocell eye
- Double front photocell eye
- Autosensor
- Overhead Sensor



Design:

- Build Options: Mild steel, chrome plated, satin chrome, polyester powder coated to a choice of RAL colours or 304 grade stainless steel
- Can be set to open at either 180° or 90°
- 10rpm motor, which fully opens the gate in 3 seconds
- Can be easily integrated with railings/barriers providing the same look and feel throughout the desired area
- 3 Top cap options available: Domed, Directional or Flat

Order Information

All controlled units are supplied complete with Push Button. Other control methods by quotation only.

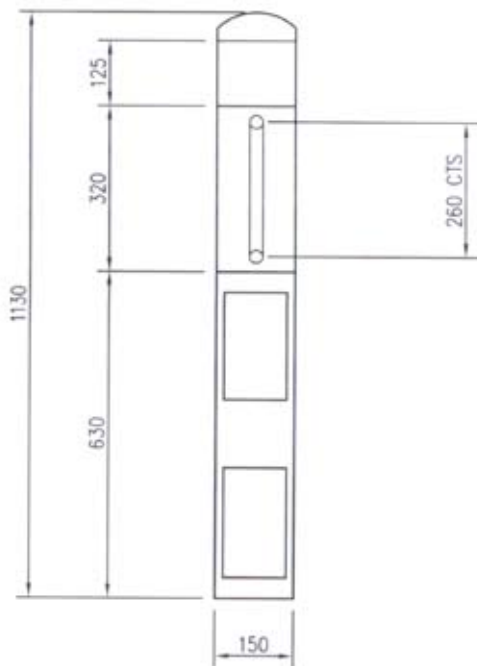

Directional Top Cap:



Rotogate with full depth arm

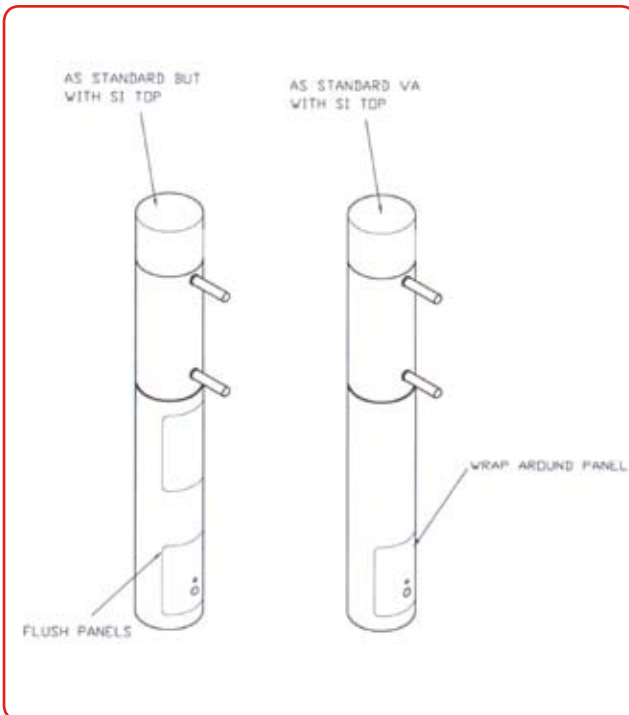

This Rotogate has the option of a full depth arm with perspex infill panel which is more suited to leisure/corporate environments as it has the added benefit of being fully DDA compliant as it offers full access to disabled users. Rotogate is available in single left and right hand opening modes or double interconnecting units.

Control possibilities are:-

Front Sensor options

- Single front photocell eye
- Double front photocell eye
- Autosensor
- Overhead Sensor

Design:

- Build Options: Mild steel, chrome plated, satin chrome, polyester powder coated to a choice of RAL colours or 304 grade stainless steel
- Can be set to open at either 180° or 90°
- 10rpm motor, which fully opens the gate in 3 seconds
- Can be easily integrated with railings/barriers providing the same look and feel throughout the desired area
- 3 Top caps available: domed, directional or flat

Order Information

All controlled units are supplied complete with Push Button. Other control methods by quotation only.



Rotogate SI



The Rotogate SI provides a very prestigious yet secure access control solution that is very suitable in front of house locations. This attractive, robust unit incorporates all of the working mechanisms neatly within the gate column, making it compact and user friendly. The Rotogate SI provides secure closure for passageways and well suited for checkpoints where high security and attractive design are both equally important. Designed specially to provide access for all, as it has the added benefit of being fully DDA compliant as it offers full access to disabled users. The Rotogate SI will provide additional access whilst the stainless steel finish means that it will compliment the design of the main installation.

Our Rotogate SI is packed with many features that make access control more integrated and less obtrusive. It has the flexibility to be integrated with a variety of control systems from a simple manually operated push button to more sophisticated fully automatic active infra-red or autosensor devices - see our information on control mechanisms for further information. Connection to a customer's own bespoke control system, e.g. fire alarm, computer system, etc. comes as standard. Another great feature of the Rotogate is that it will automatically reset from the breakout position within 3 seconds (the breakout force required can be varied between 60-120 newton metres to suit environments) and has in-built intelligent software that activates a 'sleep mode' if it cannot perform a function after 3 failed attempts. Our product is complying with the code of practice for "Safety at powered doors for pedestrian use" BS7036.

The Rotogate SI is available in single left and right hand opening modes or double interconnecting units.

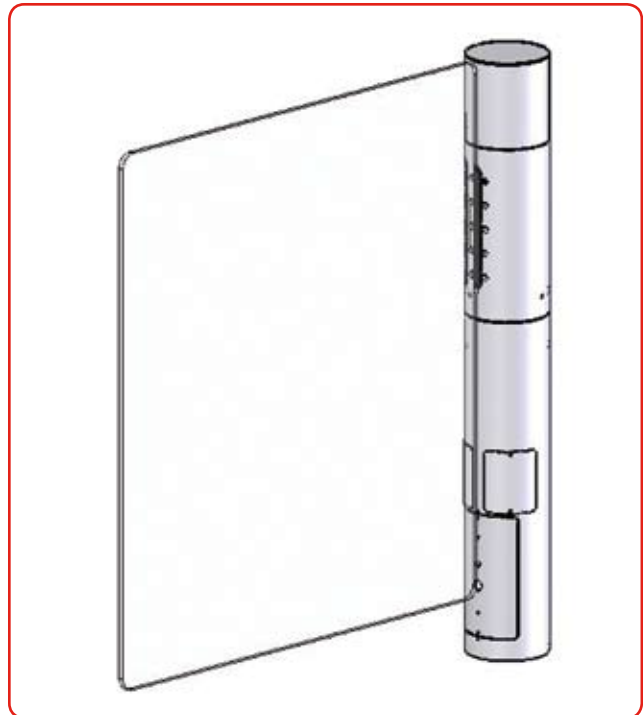



Control possibilities are:-

Front Sensor options:

- Single front photocell eye
- Double front photocell eye
- Autosensor
- Overhead Sensor

Standard and optional features;

Design:

- 304 stainless steel body with 10mm thick toughened safety glass (1000mm full depth)
- Can be set to open at either +/- 90° or customised to suit
- 3rpm motor as standard, which fully opens the glass arm gate in 8 seconds
- Gate arm driving torque is limited to just 8Nm
- (9.81N = 1Kg force)

Order Information

Rotogate SI is supplied with 2 Push Button control & arm width up to 900mm.

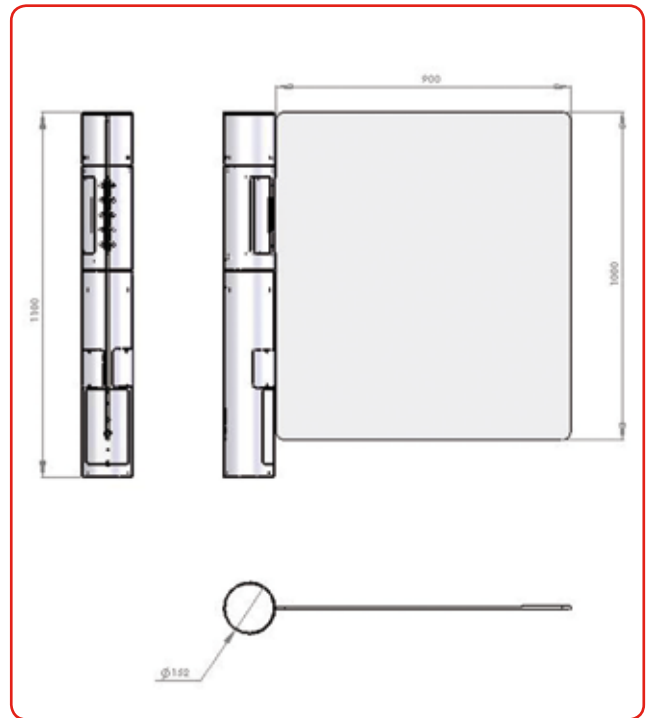
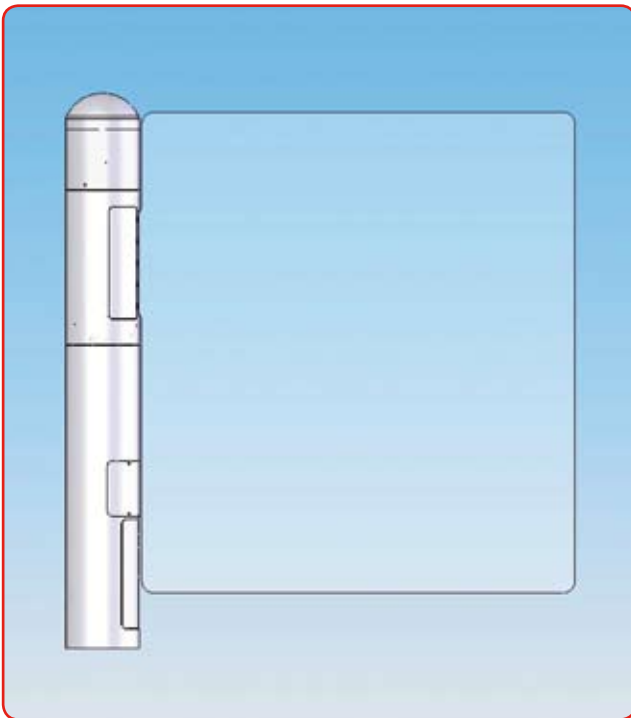

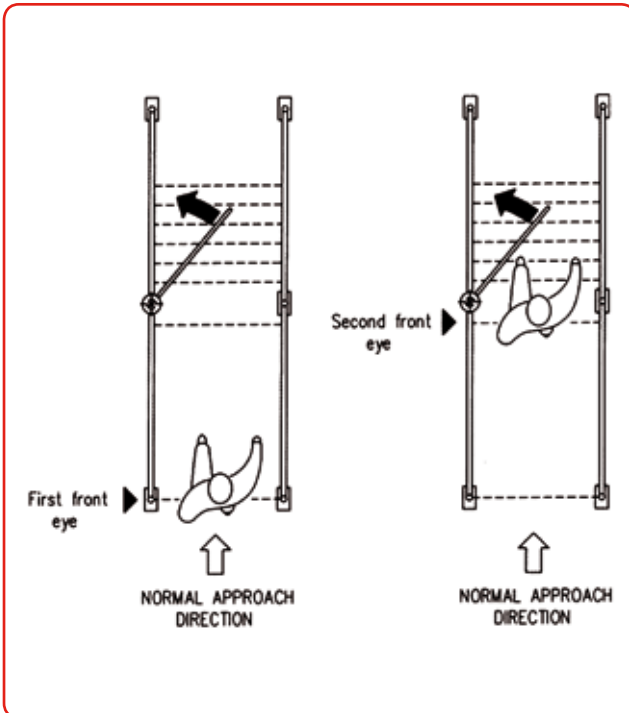

ITAB MK automatic gates can be interfaced with a variety of control systems, from a simple manually operated push button to more sophisticated fully automatic ultrasonic or autosensor devices. Connection to a customer's own bespoke control system, for example a fire alarm or computer system, is also possible. Standard control mechanisms are described as below:

Photocell Eyes

Photocell eyes are a reliable and effective form of gate control. The eyes act as a presence sensor, sending out a beam of invisible infrared light directed at a reflective strip placed opposite the photocell eye.

1. First Front Eye

The first front eye is positioned 100mm above the finished floor level in the upright post supporting the lead-in rails at a recommended minimum of 1.2 metres from the gate body. When a person or object breaks the invisible beam of light, the gate will open and close again after a pre-set time delay. Should a person or object remain in the path of the light beam, the gate will remain open.

2. Second Front Eye

Supplementing and operating in the same manner as the first front eye, the second front eye is typically positioned on a cross rail close to the gate body. If the gate begins to close before the customer has passed it, activation of the second front eye will re-open it.

3. Six Eye Rear Safety Zone

The six eye rear safety zone is highly recommended and offers increased safety for pedestrians in the path of the gate arm. If any one of the six eye beams is broken, the gate arm stops moving. Detection of a presence in the rear safety zone will override any other signals. The gate will not function until the safety zone area is cleared of any presence and a pre-set time delay has elapsed.

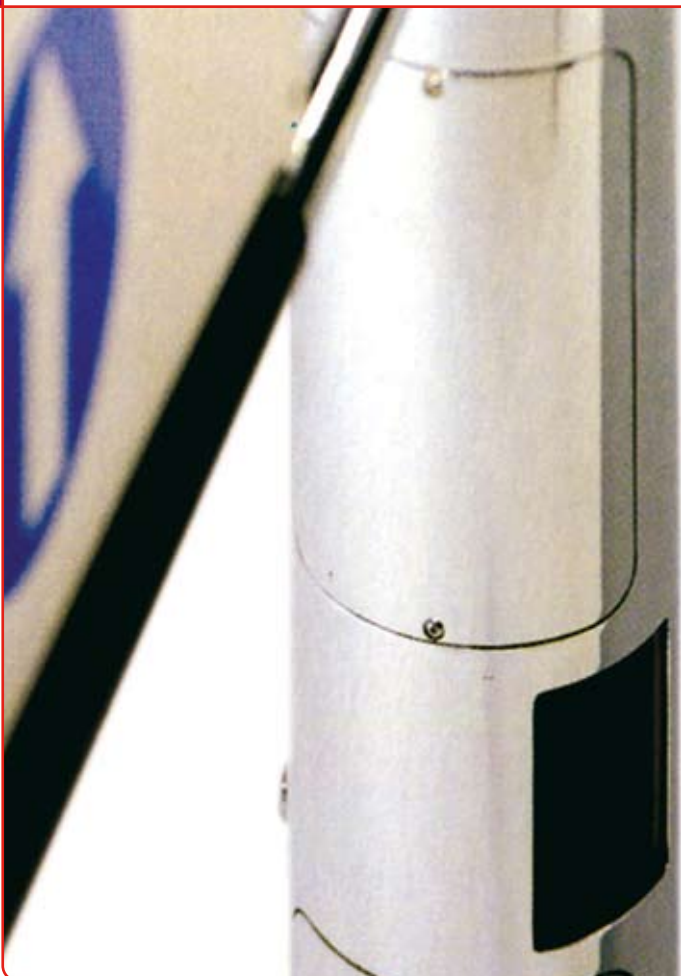

4. Reverse Action Eye

The reverse action eye is exclusively for use with reverse action gate configurations, and is incorporated into the lead out barrier rail. Reverse action gate configurations allow unrestricted flow in one direction whilst inhibiting flow in the opposite direction. Upon detection of an exit attempt in the restricted direction, the gate arm closes and remains closed until the reverse action eye detects return movement in the permitted direction, or the pre-set time delay elapses.

A minimum of 3 metres is required between the reverse action eye and the gate body so that a person attempting to run out of the store may still be stopped.

5. Push Button

A push button is the simplest means of controlling a gate. It can be used in any application where direct control or monitoring of persons through the gate is required.

6. Autosensors

Autosensors are generally used in applications where space is limited or a more open environment is desired. One internally mounted sensor is required per gate. Autosensors are only able to detect movement and so cannot be used as a presence detector i.e. in place of a safety detector. Each sensor is factory-set, but due to the variable nature of each installation, it may be necessary to alter the detection range on site. Care should be taken when positioning an autosensor, as cross pedestrian traffic flow may lead to false opening of the gate.

7. Ultrasonic Sensors

Ultrasonic sensors are presence detectors which can be used where it is not desirable to use lead-out rails with a six pack rear safety. One internally mounted sensor is required per gate. As the detection zone is not visible, consideration must be given to ensure that it is kept free of obstructions because this will prevent the gate from opening.

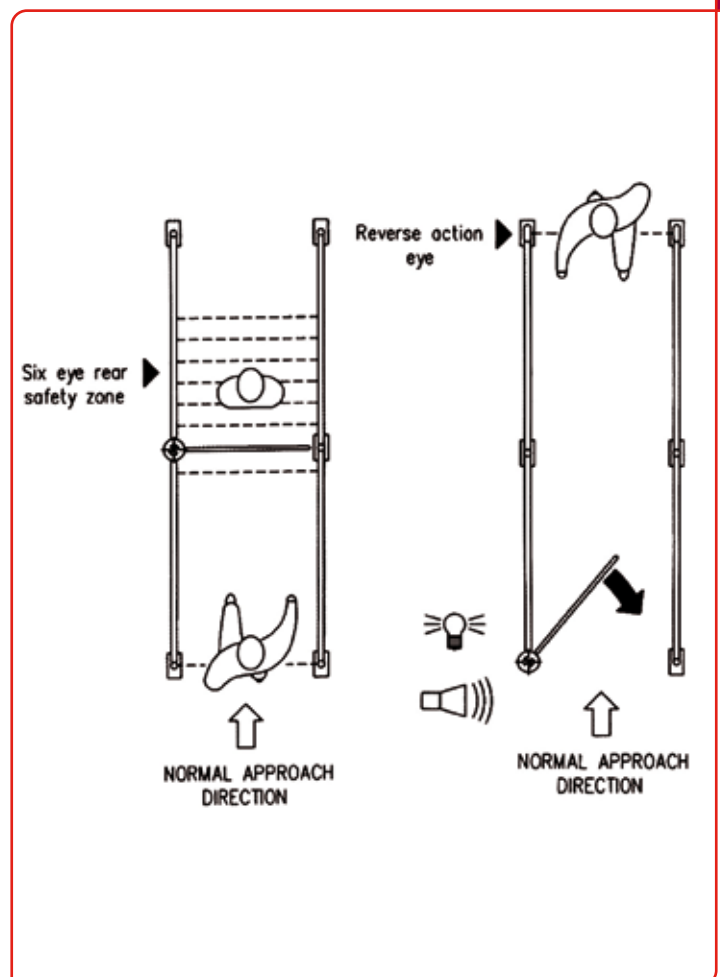

Control Mechanisms - Overhead Sensor



CUSTOMER GUIDANCE

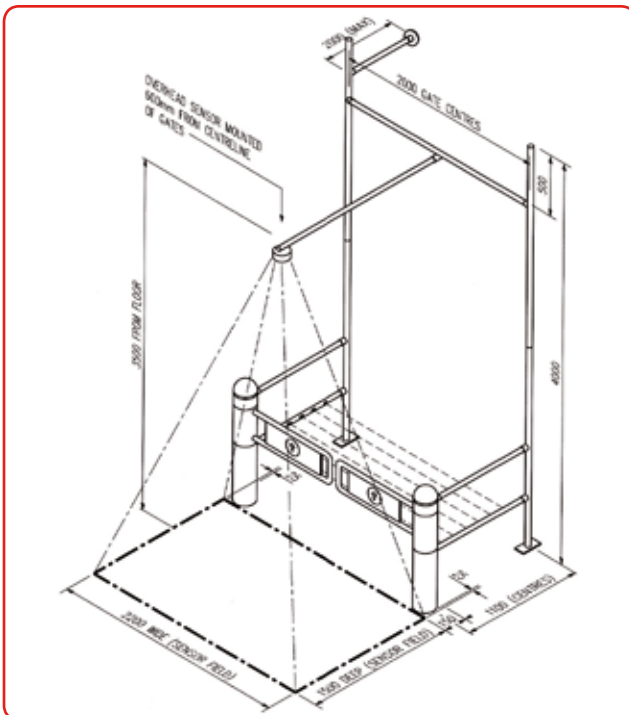

This control system offers the security benefit of unobtrusive automated entrance gates which are operated based on motion and presence in order to open/close the gates as required.

The overhead sensor can be installed in a variety of applications from recessed into the ceiling to supported by unistrut (see photo for illustration), in order to complement the site environment. Thus removing need for any barriers whilst giving finite control.

The overhead sensor detection pattern is made up of 4 rows, each of which has 6 detection spots. This provides a very dense detection area of 24 detection spots.

The sensor is microprocessor controlled, providing programmable Presence Timer (2, 15, 60 secs).

It has a pattern depth and width which are adjustable using mounting heights, dip switches, pattern angle adjustments, it also continuously monitors itself with its self-diagnostic function, and has 4 frequency settings to avoid cross interference between sensors in close proximity.

Order Information

Available fully installed



Standard and optional features;

Model	HR82C Motion & Presence Sensor
Detection Method	Active Infrared Detection
Maximum Installed Height	2.0m to 4.0m
Pattern Adjustments	Pattern Width (Area mask) Pattern Depth [Row] (1 to 4 Rows) Pattern Depth [Angle] (+/-10deg) Left/Right pattern [Angle] (+/-10deg) Sensitivity, Mounting Height
Power Supply	HR82C-B*:AC/DC 24V +/-10% HR82C-A*:AC/DC 12V +/-10%
Power Consumption	2.5VA Max. at AC, 100mA Max. at DC
Output Contact	Standard Relay type: 1a - N.O. DC50V 0.1A (Resistor Load) Option Relay type: 1b - N.C. DC50V 0.1A (Resistor Load)
Output Holding Time	Approx. 0.5sec's
Power/Operation Indicator LED	(Red) Norm=ON, Detec=Off, Fault=Frash
Reflection Monitor LED	(Yellow) Norm.=OFF, High Reflection=ON
Temperature Range	10°~+55°C
Weight	Approx. 340g (0.75lbs)
Accessories	Cable 3.0m, Instructions, Mounting Template Area Mask x2